



# TBL/TBS

BLOWER COIL UNITS  
REDUCED-FOOTPRINT, VERTICAL

# TBL/TBS BLOWER COIL UNITS REDUCED-FOOTPRINT, VERTICAL

## Table of Contents

---

Features and Benefits.....	3
Construction Features.....	4
Features and Options.....	5
Applications.....	6
Coil and Filter Data .....	8
Coil Data.....	8
Electric Heat.....	10
Electric Data.....	11
Typical Installations .....	13
Unit Discharge Options.....	14
Fan Performance Curves.....	14
Dimensional Data .....	17
Guide Specifications .....	23



### NOTES:

- Titus offers TEAMS selection software, selection program for complete unit, coil and sound selection
- See your representative or visit our website at [www.titus-hvac.com](http://www.titus-hvac.com) for more information
- Some drawings are not shown in this catalog. Drawings are not for installation purposes.
- ETL Report Number 510580
- MEA Number MEA 55-98-E applies to all units with any combination of chilled water or R-22 direct expansion coils and either hot water coils, steam coils, or electric heat
- All data herein is subject to change without notice



## Features and Benefits

---

### DESIGN FLEXIBILITY

Titus TBL/TBS Belt Drive Blower Coils give maximum flexibility for selection and installation where extreme space restrictions exist. The units are designed with a slant coil and all front access to minimize the space used for installation.

The units are designed to exceed the stringent quality standards of the institutional market, while remaining cost competitive in the light commercial segment of the market.

Titus Belt Drive Blower Coils set the new standards for quality, flexibility, and competitive pricing.

### OPTIONAL COMPONENTS

The extensive variety of standard options available on the TBL/TBS units are where you find the versatility to fit any HVAC system designer's needs.

Options include: Mixing boxes with standard low-leak dampers, blow-thru electric heat with or without single point power connection. All electric heat units are listed with ETL as an assembly and carry the cETL label.

High efficiency motors, starters, disconnects and fusing mean easier coordination between mechanical and electrical trades.

Coil options allow for 4 or 6 row cooling coils.

### LOWER INSTALLATION COSTS

All TBL/TBS model blower coils are shipped completely assembled, reducing field installation time and labor. All units are thoroughly inspected and tested prior to shipment, eliminating potential problems at startup. Motor wiring is brought to a junction box and terminated. The junction box is located on the outside of the unit casing, reducing electrical hook-up time.

A wide variety of fan discharge configurations allow for increased flexibility and easier installation on the jobsite, resulting in cost reductions by eliminating expensive elbows, etc.

### QUALITY PRODUCT

TBL/TBS model blower coils are constructed from 18 gauge galvanized steel. This metal surpasses the ASTM 125 hour salt spray test for corrosion and rust. Insulation is 1 inch thick, 1.6 pound per cubic foot scrim reinforced foil faced insulation, which is glued, pinned and taped for maximum positive adhesion. Insulation complies with UL 181, ASTM-C1071, NFPA 90A and 90B and meets bacteriological standard ASTM-C665 and C1136 for mold, mildew and humidity resistance.

All units, with or without electric heat, are cETL listed and labeled. All wiring is in compliance with NEC, assuring safety and quality for the owner.

# TBL/TBS BLOWER COIL UNITS REDUCED-FOOTPRINT, VERTICAL

## Construction Features

### MODELS TBL/TBS (TBS shown)

Models TBL and TBS blower coils have many standard and optional features which are unique to the industry (see page 5 for a complete listing).

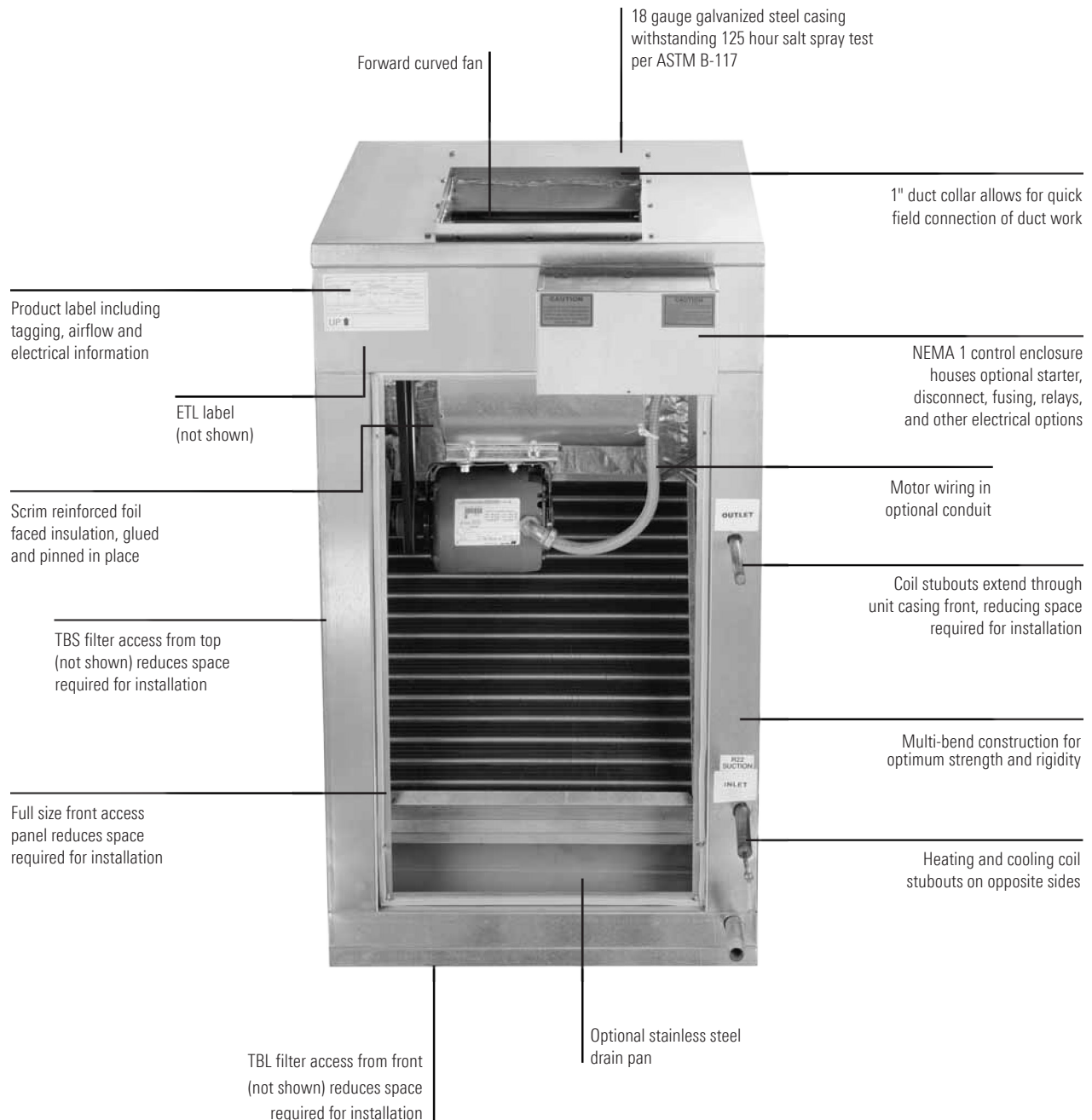



## Features and Options

### STANDARD FEATURES

#### CONSTRUCTION

- Galvanized steel cabinet construction, minimum 18 gauge
- 1" thick 1.6 lb/ft<sup>3</sup> scrim reinforced foil faced insulation, glued, taped and pinned in place
- 1" supply duct collars
- Gasketed, removable access panel sized for easy handling
- Galvanized steel drain pan with 1 1/8" ODM copper pipe outlet
- Left and right hand arrangement

#### FAN ASSEMBLY

- Forward curved (double width, double inlet) fans
- Statically and dynamically balanced
- Solid steel shafting
- Ball bearings with a minimum design average life (L50) of 100,000 hours

#### FAN MOTOR AND DRIVE

- NEMA design ODP motors
- 1750 RPM single speed, 60 Hertz
- Single phase motors with inherent thermal protection
- Three phase motors
- Rigid mount adjustable motor base
- Standard cross section "V-belt" drive with 1.2 service factor
- Adjustable pitch motor pulley and fixed pitch blower pulley

#### COILS

- AHRI 410 certified and labeled
- 1/2" O.D. seamless copper tubes
- Collared and corrugated aluminum fins
- Manual air vent plug on all water coils
- 300 PSIG working pressure at 200°F
- Steam coils rated at 15 PSIG maximum
- Copper ODM sweat connections
- 0.016" tube wall on water and evaporator coils
- 0.025" tube wall on steam coils
- High efficiency aluminum fin surface for optimizing heat transfer, pressure drop and carryover

#### FILTERS AND FILTER RACK

- Top access flat filter rack (TBS only)
- Front access filter rack (TBL only)
- Standard size 2" nominal throwaway filters

#### ELECTRICAL

- Fan motor wired and terminated to J-box
- All units ETL listed in compliance with UL/ANSI
- Standard 1995

### OPTIONAL FEATURES

#### CONSTRUCTION

- Stainless steel drain pan with 1" MPT galvanized pipe outlet
- External rubber-in-shear or spring type vibration isolators, floor mount
- Fan discharge arrangements
- Discharge plenum w/ dbl. deflection discharge grille
- Access panel with lift and turn fasteners
- Double wall access panel w/lift and turn fasteners
- Return plenum with removable panels (TBL only)
- Base rails with rigging slots factory assembled and installed

#### FAN MOTOR AND DRIVE

- TEFC motors
- High efficiency motors

#### COILS

- 4 and 6 row chilled water or DX coils
- 1 and 2 row hot water coils
- 1 and 2 row hot water or standard steam coils in discharge coil section only
- Hot water coil in preheat or reheat position
- Stainless steel coil casings
- 0.025" tube wall on water and evaporator coils
- Auto air vents on water coils

#### FILTERS AND FILTER RACK

- Side access filter rack (TBS only)
- 2" pleated filter
- Spare throwaway or pleated filters

#### INLET DAMPER SECTION (TBS REAR RETURN UNIT)

- Factory assembled and installed
- Heavy gauge galvanized steel formed blade dampers
- Low-leak dampers with extruded vinyl blade seals and flexible metal jamb seals
- Parallel blade operation
- Interconnecting damper linkage

#### ELECTRICAL

- Motor wiring in conduit
- Motor starter (contactor with overload for three phase; contactor for single phase), factory installed (mounted and wired)
- Door interlocking disconnect switch (non-fused) (with main fusing)
- Hand off auto switch (HOA)
- Main fusing

#### ELECTRIC HEAT SECTION

- Factory mounted electric heater with single point power connection, ETL listed as an assembly (see page 10)

# TBL/TBS BLOWER COIL UNITS REDUCED-FOOTPRINT, VERTICAL

## Applications

### APPLICATION CONSIDERATIONS

Models TBL/TBS Belt Drive Blower Coils offer a wide range of application flexibility, while maintaining a simple, easy to install unit design. These units are intended to provide comfort cooling and heating within a small footprint. They may be applied in many types of building structures including schools, office buildings, hospitals, condominiums, assisted living facilities, apartments or stores. Applications can be constant or variable volume.

There are many applications the TBL/TBS product can be utilized. Some examples are listed below.

#### Constant volume applications:

- Two-pipe hydronic system for cooling and/or heating
- Two-pipe hydronic cooling system with electric heat
- Four-pipe system with dedicated heating and cooling coils
- Direct Expansion (DX) split systems with hydronic heat
- Direct Expansion (DX) split systems with electric heat

#### Variable volume applications:

- Two-pipe hydronic system for cooling and/or heating
- Two-pipe hydronic cooling system with electric heat
- Four-pipe system with dedicated heating and cooling coils

### ACOUSTICS

Control of noise within both occupied and unoccupied spaces has become increasingly important to designers and building owners/occupants. Proper consideration must be given to placement of indoor air conditioning units, particularly in the occupied space. Inherent flexibility of the fan and coil combination in the vertical configuration allows application in sound-sensitive areas. In such instances, a fan running at a low speed with a high capacity coil normally yields satisfactory results. It also may be desirable to select a larger nominal capacity unit and operate it at a less than nominal airflow for further acoustic benefit.

Three phase motors are recommended for sound-sensitive applications to avoid potential single phase motor hum. Unit operation in the stall region of the fan curve is not recommended since it may cause unsatisfactory noise levels and excessive unit vibration.

### INSTALLATION

These floor mounted units can be installed with external vibration isolation on a base rail (TBS) or on a return plenum (TBL) at the corner points. This requires flex connections at the corner brackets, ductwork, electrical connections and piping connections. One of the most important and basic IAQ issues is condensate management. The first step to ensure trouble-free operation is proper installation. It is very important that the unit be mounted high enough so that the condensate drain from the unit may be properly trapped. Please refer to the TBL/TBS IOM Manual for specifics on this issue. As with all HVAC systems, these units should be installed according to all applicable ASHRAE standards, SMACNA and local code requirements.

### OPERATING LIMITATIONS

Units must not be operated above maximum fan speed or unit airflow as listed in the Fan Performance section of this catalog. Unit operation at greater than maximum fan speed could drastically reduce bearing life and may result in a catastrophic wheel failure. Operating at greater than the maximum allowable airflow in the cooling mode may result in unsatisfactory operation due to moisture carry over from the coil. In addition, it is often not economical to operate a unit at its maximum fan speed due to the greater motor power requirements.

Units with electric heat should not be operated with leaving air temperature greater than 104°F (40°C), to prevent excessive leaving air temperatures and electric heat limit trips. A hydronic (or steam) coil and electric heat should not be operated simultaneously to prevent excessive leaving air temperatures and limit trips. Electric heat units are equipped with a high limit lockout switch that disables the electric heater if the temperature of the hydronic (or steam) coil is greater than 104°F (40°C).

Water coils must not be operated above a fluid velocity of 8 ft./sec. to reduce the possibility of velocity induced erosion and flow noise. Water coils must not be operated below a fluid velocity of 1 ft./sec. to prevent degraded coil performance caused by laminar flow. These high or low fluid flow rates may not be included in the AHRI coil certification.

## Coil and Filter Data

### COIL FACE AREA AND FILTER DATA

Unit Size	Internal Cooling And Heating Coils	Discharge Section Heating Coil	2" Filters (Quantity) and Size	Filter Face Area
08	2.1 [0.20]	2.1 [0.20]	(1) 16 x 20 x 2 [406 x 508 x 51]	2.2 [0.20]
12	2.8 [0.26]	2.1 [0.20]	(1) 20 x 20 x 2 [508 x 508 x 51]	2.8 [0.26]
16	3.6 [0.33]	3.2 [0.30]	(1) 24 x 24 x 2 [610 x 610 x 51]	4.0 [0.37]
20	4.8 [0.45]	3.2 [0.30]	(1) 24 x 24 x 2 [610 x 610 x 51]	4.0 [0.37]
25	5.7 [0.53]	4.6 [0.43]	(1) 24 x 24 x 2 [610 x 610 x 51] (1) 12 x 24 x 2 [305 x 610 x 51]	6.0 [0.56]
30	6.8 [0.63]	5.7 [0.53]	(1) 24 x 24 x 2 [610 x 610 x 51] (1) 12 x 24 x 2 [305 x 610 x 51]	6.0 [0.56]

Notes:

1. Standard filters are 2" throwaway; optional filters are 2" pleated
2. Filter sizes are nominal and standard size, measured in inches [millimeters]
3. Coil and filter face areas are measured in square feet [square meters]

### NOMINAL COIL CONNECTION SIZES

Unit Size	Coil Type											
	Water				Steam				Refrigerant			
	1 Row	2 Row	4 Row	6 Row	1 Row		2 Row		4 Row		6 Row	
					STM.	COND.	STM.	COND.	Liquid	Suction	Liquid	Suction
08	5/8 [16]	5/8 [16]	7/8 [22]	7/8 [22]	1 1/8 [29]	7/8 [22]	1 1/8 [29]	7/8 [22]	5/8 [16]	5/8 [16]	5/8 [16]	5/8 [16]
12	5/8 [16]	5/8 [16]	7/8 [22]	7/8 [22]	1 1/8 [29]	7/8 [22]	1 1/8 [29]	7/8 [22]	5/8 [16]	7/8 [22]	5/8 [16]	7/8 [22]
16	5/8 [16]	5/8 [16]	7/8 [22]	1 1/8 [29]	1 1/8 [29]	7/8 [22]	1 3/8 [35]	1 1/8 [29]	5/8 [16]	7/8 [22]	5/8 [16]	7/8 [22]
20	5/8 [16]	5/8 [16]	7/8 [22]	1 1/8 [29]	1 3/8 [35]	1 1/8 [29]	1 3/8 [35]	1 1/8 [29]	5/8 [16]	7/8 [22]	5/8 [16]	7/8 [22]
25	5/8 [16]	7/8 [22]	1 1/8 [29]	1 3/8 [35]	1 3/8 [35]	1 1/8 [29]	1 5/8 [41]	1 1/8 [29]	5/8 [16]	7/8 [22]	5/8 [16]	1 1/8 [29]
30	7/8 [22]	7/8 [22]	1 1/8 [29]	1 3/8 [35]	1 5/8 [41]	1 1/8 [29]	1 5/8 [41]	1 1/8 [29]	5/8 [16]	1 1/8 [29]	5/8 [16]	1 1/8 [29]

Notes:

1. Water coils are based on Standard GPM Circuiting. Consult factory for applications requiring special circuiting
2. For other selections, refer to Titus selection software, TEAMS
3. Refrigerant coil connection sizes for single circuit coils and may vary with application. Contact Titus for double circuit coils
4. All dimensional data is outside diameter (O.D.), measured in inches [millimeters]
5. See page 8 for a list of standard and optional features of the coils



# TBL/TBS BLOWER COIL UNITS REDUCED-FOOTPRINT, VERTICAL

## Coils Data

### COILS

Titus manufactures hot water, chilled water, direct expansion (DX), and standard steam coils for specific application with all Model TBL/TBS blower coils. AHRI 410 certified and labeled, and strict on-site inspection before, during, and after installation guarantees the highest quality and performance available.

### STANDARD FEATURES

- Designed, manufactured and tested by Titus
- AHRI 410 certified and labeled
- ½ O.D. seamless copper tubes
- High efficiency aluminum fin surface for optimizing heat transfer, pressure drop and carryover
- Mechanically expanded copper tubes leak tested to a minimum 450 PSIG air pressure under water
- Manual air vent plug on all water coils
- Copper ODM sweat connections
- 300 PSIG working pressure at 200°F
- Evaporator coils are factory sealed and charged with a minimum of 5 PSIG nitrogen or refrigerated dry air
- Steam coils rated at 15 PSIG maximum operating pressure at above 35°F
- 0.016" tube wall thickness (0.025" on steam)

### OPTIONAL FEATURES

- Stainless steel coil casings
- Automatic air vents on water coils
- Elevated working pressure ratings
- Heat pump compatible cooling coils
- Double circuit DX coils (intertwined with 50-50 split)
- 0.025" tube wall thickness



### COMPONENT STATIC PRESSURE LOSS – INCHES W.G.

Unit Size	Nominal CFM	Cabinet	Filter (2" T/A)	Coil						Inlet Damper Section	Electric Heat Section
				Internal				External			
				1 Row	2 Row	4 Row	6 Row	1 Row	2 Row		
08	800	0.09	0.25	0.05	0.10	0.31	0.46	0.05	0.10	0.04	0.05
12	1200	0.09	0.25	0.06	0.12	0.37	0.55	0.10	0.19	0.06	0.05
16	1600	0.10	0.25	0.06	0.12	0.38	0.58	0.08	0.15	0.09	0.05
20	2000	0.11	0.25	0.06	0.11	0.35	0.52	0.11	0.22	0.05	0.05
25	2500	0.12	0.25	0.06	0.12	0.38	0.57	0.09	0.17	0.06	0.05
30	3000	0.14	0.25	0.06	0.12	0.38	0.57	0.08	0.16	0.08	0.05

#### Notes:

1. All static pressures are at nominal CFM
2. Coil static pressure for standard coil, 10FPI at 80/67 EAT and 45° EWT with 10° rise
3. For 12FPI, refer to Titus selection software.
4. Filter static pressure based on 50% loaded filter
5. If pleated filters are used in lieu of throwaway, the filter static pressure loss is 0.35

## Electric Heat

### STANDARD FEATURES

- Galvanized steel casing
- Flanged construction for direct unit mounting, in blow-thru configuration
- Listed for zero clearance installation
- Meets National Electrical Code requirements
- Ni-Chrome wire in ceramic insulators
- Stainless steel element terminals and hardware
- Element support brackets on maximum 3 ½" centers
- Solid cover with continuous full height hinge
- Overtemperature protection
- All internal wiring rated for 105°C minimum
- Airflow switch
- Incoming line power distribution block
- ETL Listed in compliance with UL/ANSI Standard 1995
- Single point power connection
- Heater factory mounted to unit with ETL listing as an assembly

Heater AMP Calculation	
Voltage	AMPs per kW
115/1	8.70
208/1	4.81
230/1	4.35
277/1	3.61
208/3	2.78
230/3	2.51
460/3	1.26
575/3	1.00



### ELECTRICAL CALCULATIONS INFORMATION

- Contact Titus for MCA and/or MOP calculations
- Non-Fused Door Interlock Disconnect Switch shall be sized according to MCA
- Fused Door Interlock Disconnect Switch and Main Fusing shall be sized according to MOP

### OPTIONAL FEATURES

- Door interlocking disconnect switch
- Fusing (main) (per stage)
- Magnetic contactors wired for disconnecting operation
- Fan control package with heater interlock contacts (required for single point power connection)

# TBL/TBS BLOWER COIL UNITS REDUCED-FOOTPRINT, VERTICAL

## Electric Heat

Unit Voltage And Phase			Electric Heat KW Limits											
			Unit Size											
			08		12		16		20		25		30	
			Min	Max	Min	Max	Min	Max	Min	Max	Min	Max	Min	Max
Single Phase	115	kW	3	5	3	5	3	5	4	5				
		AMPs	26.1	43.5	26.1	43.5	26.1	43.5	34.8	43.5				
	208	kW	3	9	3	9	3	9	4	9	6	9	6	9
		AMPs	14.4	43.3	14.4	43.3	14.4	43.3	19.2	43.3	28.8	43.3	28.8	43.3
	230	kW	3	11	3	11	3	11	4	11	6	11	6	11
		AMPs	13.0	47.8	13.0	47.8	13.0	47.8	17.4	47.8	26.1	47.8	26.1	47.8
	277	kW	3	13	3	13	3	13	4	13	6	13	6	13
		AMPs	10.8	46.9	10.8	46.9	10.8	46.9	14.4	46.9	21.7	46.9	21.7	46.9
Three Phase	208	kW	3	13	3	16	3	16	4	16	4	16	4	16
		AMPs	8.3	36.1	8.3	44.4	8.3	44.4	11.1	44.4	11.1	44.4	11.1	44.4
	230	kW	3	13	3	18	3	18	4	18	4	18	4	18
		AMPs	7.5	32.6	7.5	45.2	7.5	45.2	10.0	45.2	10.0	45.2	10.0	45.2
	460	kW	3	13	3	20	3	20	4	26	4	26	4	26
		AMPs	3.8	16.3	3.8	25.1	3.8	25.1	5.0	32.6	5.0	32.6	5.0	32.6
	575	kW	3	13	3	20	3	20	4	26	4	26	4	26
		AMPs	3.0	13.1	3.0	20.1	3.0	20.1	4.0	26.1	4.0	26.1	4.0	26.1

Notes:

1. Electric heat sections may be shipped separate for field installation to unit
2. Factory certified submittals available upon request
3. Standard heater kW limits are maximum per unit size and voltage
4. Heater should be sized for a maximum leaving air temperature of 104°F



## Electric Data

### MOTOR ELECTRICAL DATA

Horsepower	Maximum Motor Amperage							
	Voltage							
	115/1	208/1	230/1	277/1	208/3	230/3	460/3	575/3
1/3	6.3	3.5	3.2	2.6	1.7	1.5	0.8	-
1/2	7.8	4.3	3.9	3.6	2.2	2.1	1.1	0.9
3/4	10.6	5.4	5.3	5.0	3.2	3.0	1.5	1.2
1	15.0	8.3	7.5	5.5	4.0	3.6	1.8	1.4
1 1/2	-	-	-	-	5.3	5.0	2.5	1.9
2	-	-	-	-	7.0	6.4	3.2	2.5
3	-	-	-	-	9.1	9.0	4.5	3.2

Notes:

- Actual motor nameplate AMPs may vary, but will not exceed values shown
- Consult Titus for applications requiring special motors

### UNIT WEIGHT DATA

Component	Unit Size						
	08	12	16	20	25	30	
Base Unit	125 [57]	131 [60]	160 [73]	167 [76]	231 [105]	236 [107]	
Damper Section	42 [19]	53 [24]	59 [27]	73 [33]	91 [41]	91 [41]	
Blow-thru Electric Heater	42 [19]	42 [19]	42 [19]	50 [23]	55 [25]	55 [25]	
Discharge Coil Section	35 [16]	37 [17]	49 [22]	53 [24]	76 [35]	80 [36]	
Supply Plenum	22 [10]	26 [12]	35 [16]	38 [17]	76 [35]	76 [35]	
Return Plenum (TBL)	29 [13]	30 [14]	33 [15]	35 [16]	44 [20]	44 [20]	
Coil Rows	1 Row - Dry	12 [5]	14 [6]	17 [8]	21 [10]	23 [10]	27 [12]
	1 Row - Wet	14 [6]	17 [8]	21 [10]	26 [12]	28 [13]	34 [15]
	2 Row - Dry	17 [8]	21 [10]	26 [12]	32 [15]	37 [17]	43 [20]
	2 Row - Wet	21 [10]	27 [12]	33 [15]	42 [19]	48 [22]	56 [25]
	4 Row - Dry	29 [13]	36 [16]	45 [20]	57 [26]	65 [30]	76 [35]
	4 Row - Wet	37 [17]	47 [21]	58 [26]	75 [34]	86 [39]	101 [46]
	6 Row - Dry	40 [18]	51 [23]	64 [29]	81 [37]	93 [42]	109 [50]
	6 Row - Wet	52 [24]	66 [30]	84 [38]	109 [50]	124 [56]	146 [66]

Notes:

- Unit weight data is shipping weight in pounds [kilograms]
- Discharge section includes a 2 row coil

### MOTOR/DRIVE WEIGHT DATA

Type	Motor HP						
	1/3	1/2	3/4	1	1 1/2	2	3
Single Phase	37 [17]	37 [17]	45 [20]	47 [21]	-	-	-
Three Phase	34 [15]	34 [15]	40 [18]	43 [20]	46 [21]	53 [24]	81 [37]

Notes:

- Includes motor, pulleys, belts, and motor base
- Motor/drive weight data is shipping weight in pounds [kilograms]

# TBL/TBS BLOWER COIL UNITS REDUCED-FOOTPRINT, VERTICAL

## Typical Installations

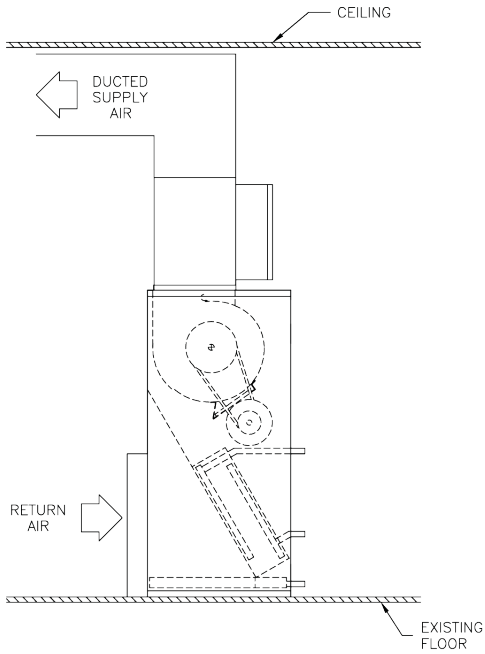

MODEL TBS WITH ELECTRIC  
HEAT MECHANICAL ROOM LAYOUT

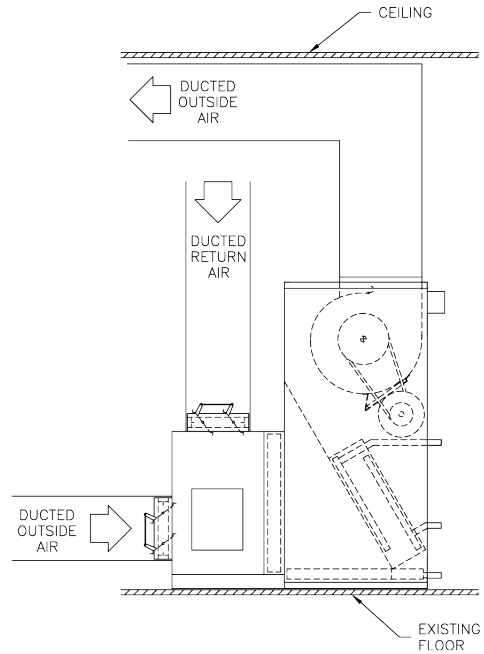

MODEL TBS, REAR RETURN WITH  
MIXING BOX - MECHANICAL ROOM LAYOUT

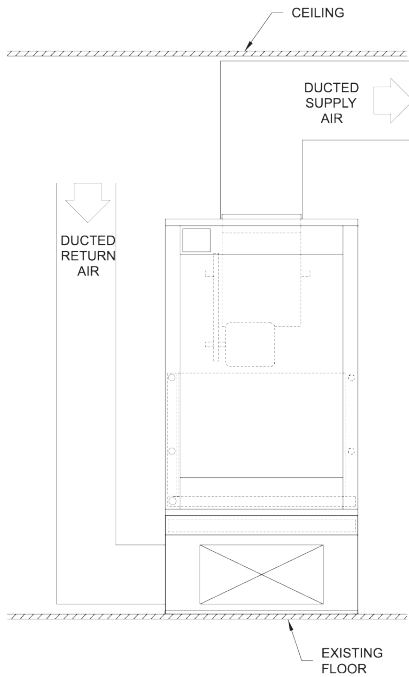

MODEL TBL, BOTTOM RETURN  
WITH RETURN PLENUM CLOSET  
OR CONFINED SPACE LAYOUT

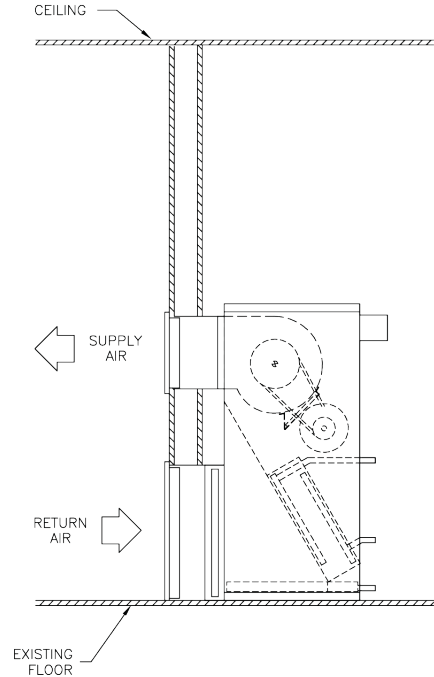

MODEL TBS, REAR RETURN  
UNIT HANDLING LOAD IN ADJACENT ROOM

## Unit Discharge Options

### MODEL TBL

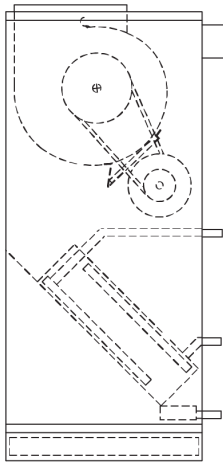

REVERSE ROTATION  
ARRANGEMENT 1

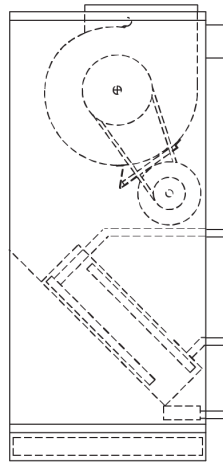

STANDARD  
ROTATION  
ARRANGEMENT 2

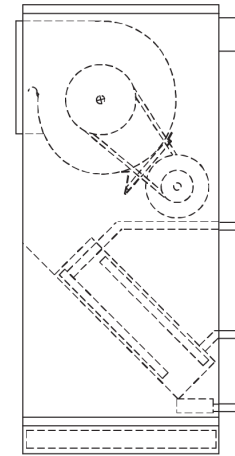

HORIZONTAL REAR  
DISCHARGE  
ARRANGEMENT 7

### MODEL TBS

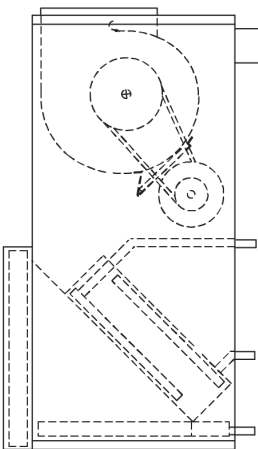

REVERSE ROTATION  
ARRANGEMENT 1

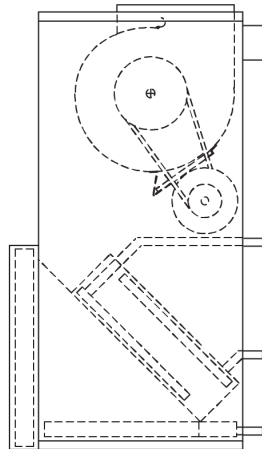

STANDARD ROTATION  
ARRANGEMENT 2

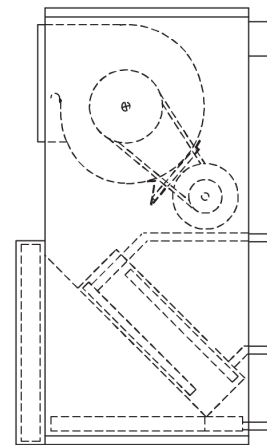

HORIZONTAL REAR  
DISCHARGE  
ARRANGEMENT 7

#### Notes:

1. Refer to Dimensional Data for unit dimensions
2. Fan arrangements are also available with inlet damper section (Model TBS) and return plenum section (Model TBL)
3. Side access filter rack standard on arrangement 7 (Model TBS)
4. Discharge heating coil section and supply plenum are not available with arrangement 7
5. All drawings subject to change without prior notice



# TBL/TBS BLOWER COIL UNITS REDUCED-FOOTPRINT, VERTICAL

## Fan Performance Curves

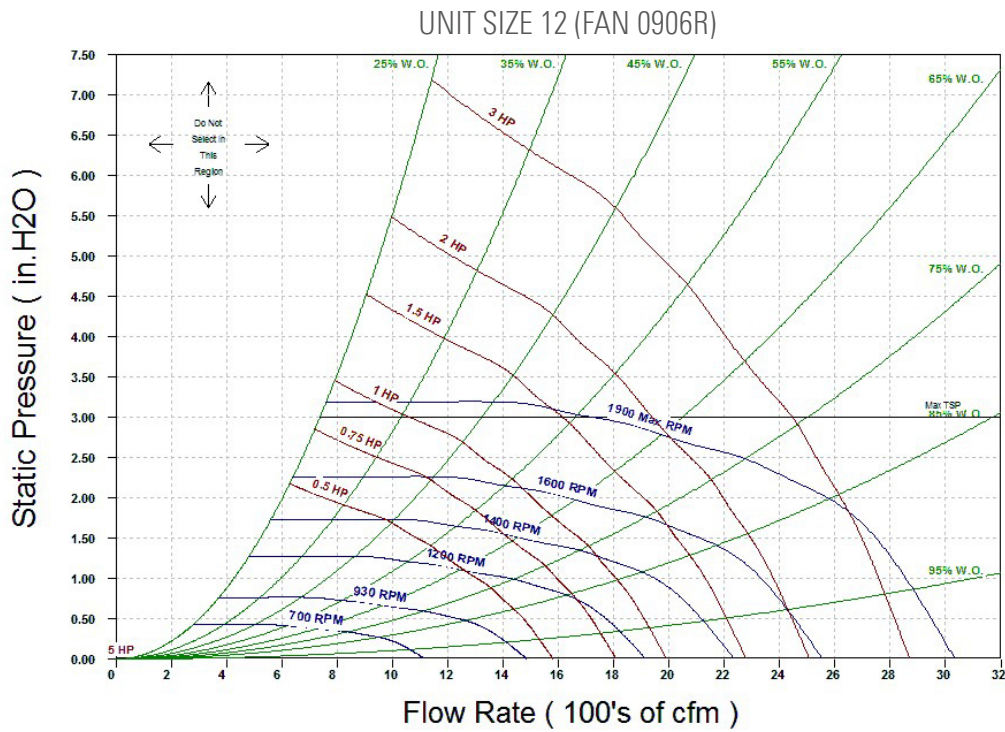
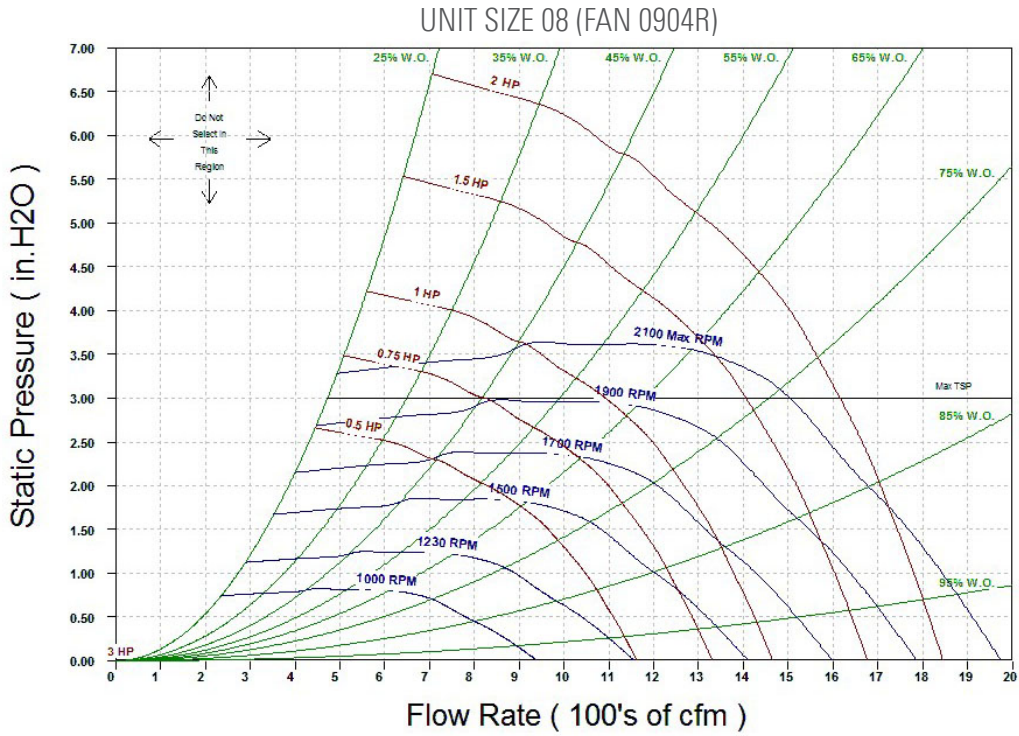

## Fan Performance Curves

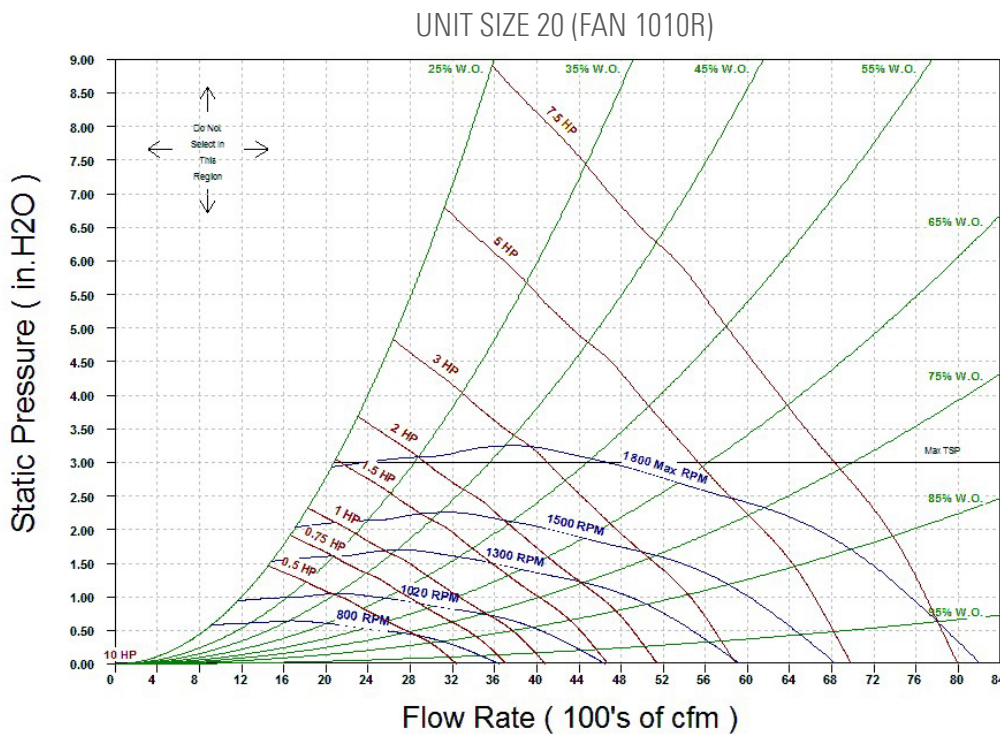
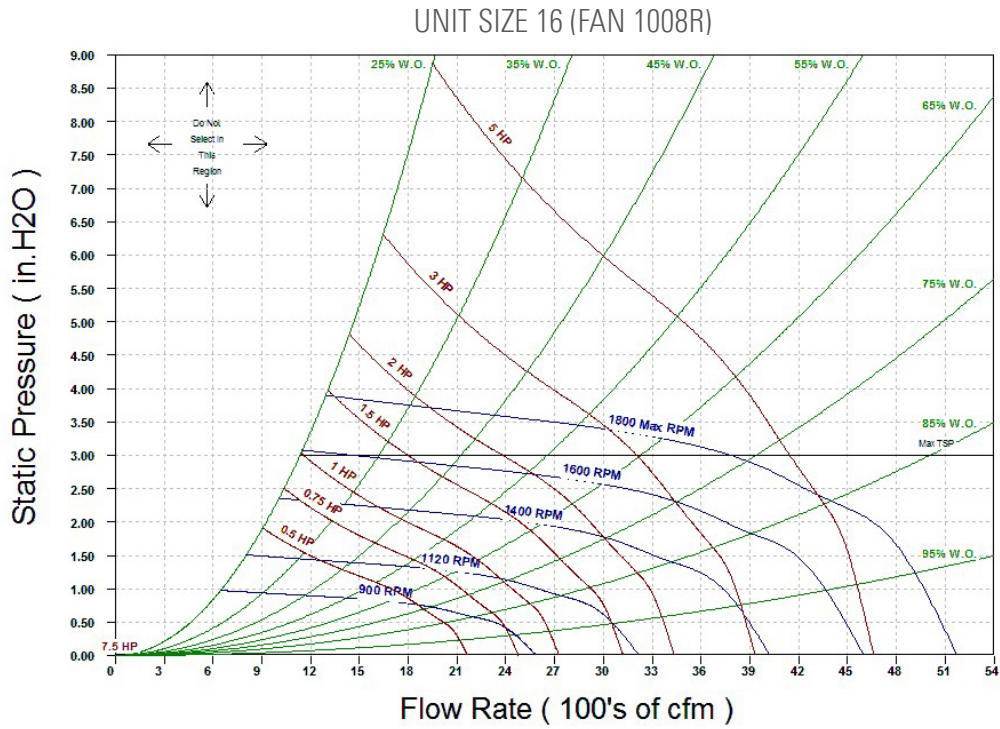



# TBL/TBS BLOWER COIL UNITS REDUCED-FOOTPRINT, VERTICAL

## Fan Performance Curves

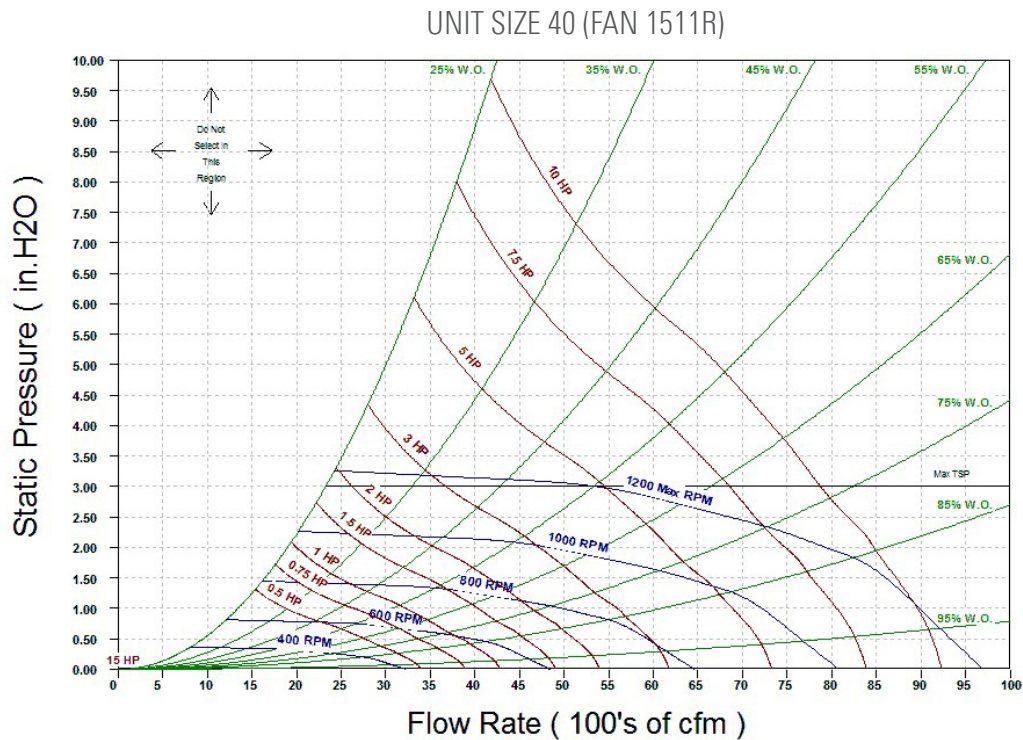
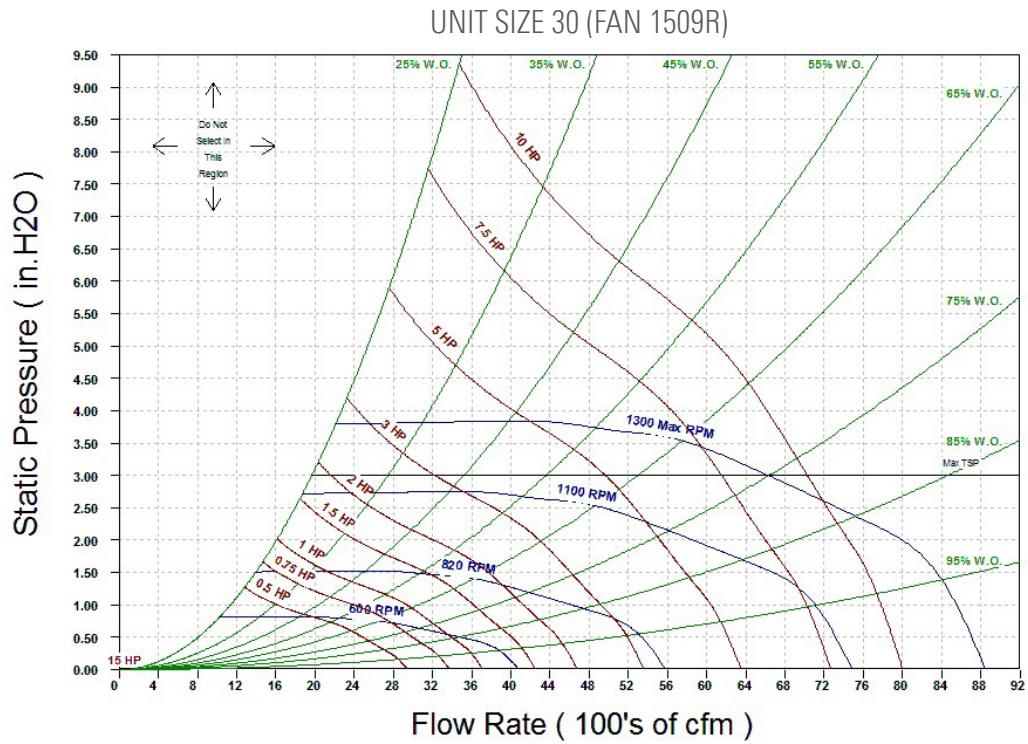



## Dimensional Data

### TBL (Bottom Return)

#### Notes:

1. All dimensions are inches [millimeters] +/- 1/4" [6mm]. Metric values are soft conversions.
2. Motor/drive location may be specified Left or Right Hand. Standard control enclosure location matches motor/drive position
3. Provide sufficient clearance to access electrical control and comply with all applicable codes and ordinances
4. Maximum total internal coil rows: 6
5. All drawings subject to change without prior notice
6. Left hand unit shown; right hand unit has CW and HW piping connections mirrored
7. Filter assembly runs the full length of the unit size
8. Drawings not for installation purposes

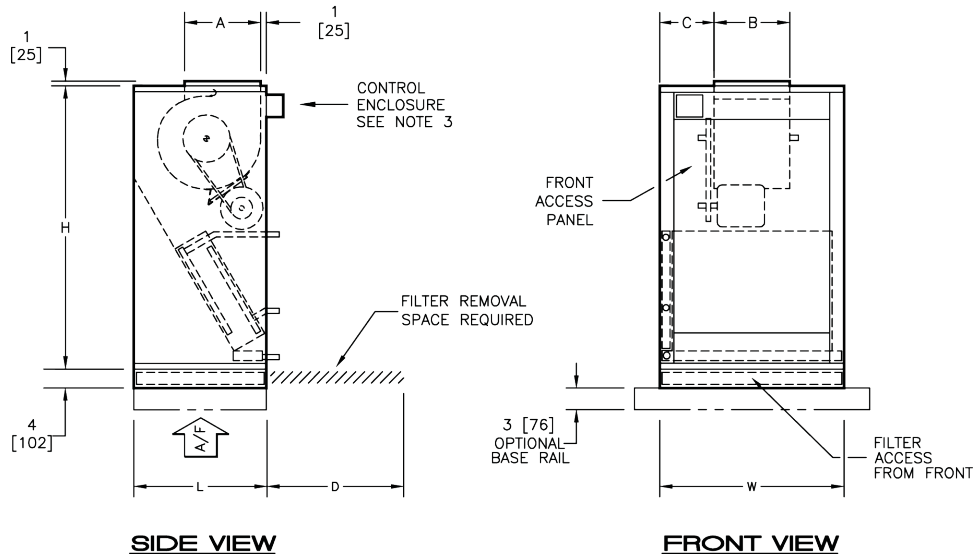
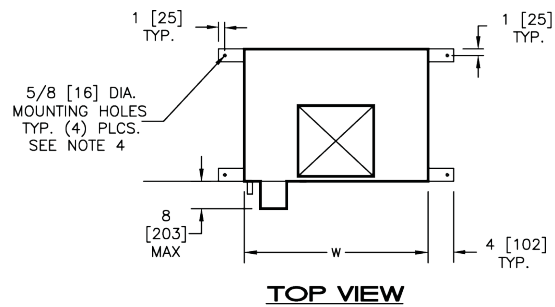

Dimensions									
Unit Size	Filter Size	Qty	H	W	L	A	B	C	D
08	16 x 20 x 2 [406 x 508 x 51]	1	46 [1168]	26 [660]	19 [483]	6 1/2 [165]	6 7/8 [175]	9 9/16 [243]	16 [406]
12	20 x 20 x 2 [508 x 508 x 51]	1	46 [1168]	26 [660]	21 [533]	7 1/2 [190]	8 1/4 [210]	8 7/8 [225]	20 [508]
16	24 x 24 x 2 [610 x 610 x 51]	1	54 [1372]	29 [737]	25 [635]	7 1/2 [190]	10 1/4 [260]	9 3/8 [238]	24 [610]
20	24 x 24 x 2 [610 x 610 x 51]	1	54 [1372]	29 [737]	28 [711]	11 3/8 [289]	13 1/4 [337]	7 7/8 [200]	24 [610]
25	24 x 24 x 2 [610 x 610 x 51]	1 Each	60 [1524]	39 [991]	28 [711]	13 1/2 [343]	12 7/8 [327]	13 1/16 [332]	24 [610]
30	12 x 24 x 2 [305 x 610 x 51]	1 Each	60 [1524]	39 [991]	28 [711]	15 1/4 [387]	15 [381]	12 [305]	24 [610]

# TBL/TBS BLOWER COIL UNITS REDUCED-FOOTPRINT, VERTICAL

## Dimensional Data

### TBS (Rear Return)

Notes:

1. All dimensions are inches [millimeters] +/- 1/4" [6mm]. Metric values are soft conversions.
2. Motor/drive location may be specified Left or Right Hand. Standard control enclosure location matches motor/drive position
3. Provide sufficient clearance to access electrical controls and comply with all applicable codes and ordinances
4. Maximum total internal coil rows: 6
5. All drawings subject to change without prior notice
6. Left hand unit shown; right hand unit has CW and HW piping connections mirrored
7. Filter assembly runs the full length of the unit size
8. Drawings not for installation purposes

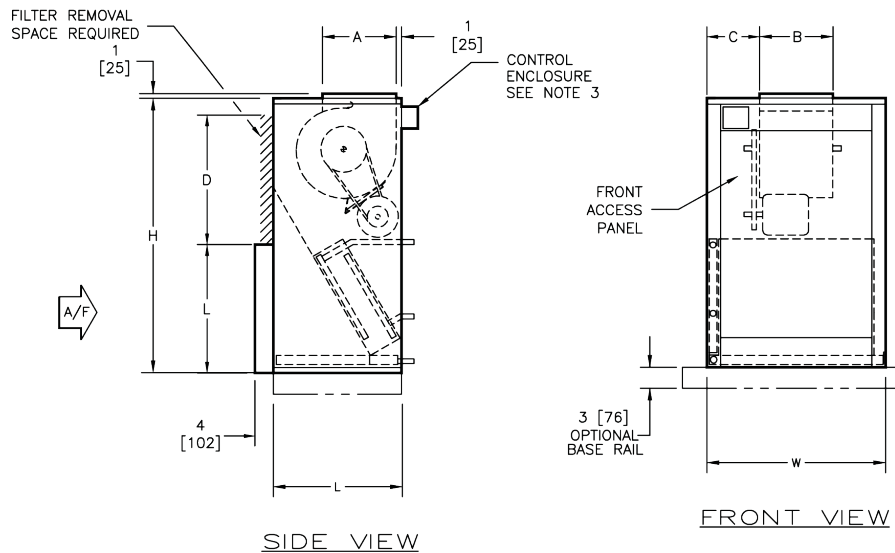
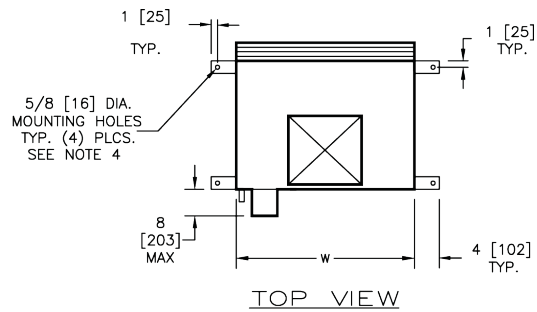

Dimensions									
Unit Size	Filter Size	Qty	H	W	L	A	B	C	D
08	16 x 20 x 2 [406 x 508 x 51]	1	46 [1168]	26 [660]	19 [483]	6 1/2 [165]	6 7/8 [175]	9 9/16 [243]	16 [406]
12	20 x 20 x 2 [508 x 508 x 51]	1	46 [1168]	26 [660]	21 [533]	7 1/2 [190]	8 1/4 [210]	8 7/8 [225]	20 [508]
16	24 x 24 x 2 [610 x 610 x 51]	1	54 [1372]	29 [737]	25 [635]	7 1/2 [190]	10 1/4 [260]	9 3/8 [238]	24 [610]
20	24 x 24 x 2 [610 x 610 x 51]	1	54 [1372]	29 [737]	28 [711]	11 3/8 [289]	13 1/4 [337]	7 7/8 [200]	24 [610]
25	24 x 24 x 2 [610 x 610 x 51]	1 Each	60 [1524]	39 [991]	28 [711]	13 1/2 [343]	12 7/8 [327]	13 1/16 [332]	24 [610]
30	12 x 24 x 2 [305 x 610 x 51]	1 Each	60 [1524]	39 [991]	28 [711]	15 1/6 [387]	15 [381]	12 [305]	24 [610]

## Dimensional Data

### TBS with Inlet Damper Section

Notes:

1. All dimensions are inches [millimeters] +/- 1/4" [6mm]. Metric value are soft conversions.
2. Motor/drive location may be specified Left or Right Hand. Standard control enclosure location matches motor/drive position
3. Provide sufficient clearance to access electrical controls and comply with all applicable codes and ordinances
4. Maximum total internal coil rows: 6
5. All drawings subject to change without prior notice
6. Left hand unit shown; right hand unit has CW and HW piping connections mirrored
7. Filter assembly runs the full length of the unit size
8. Damper drive rods are external, located on both sides of unit
9. Damper blade-to-blade linkage may extend into inlet ducts
10. Base rail shown is required on TBS units
11. Parallel blade operation is standard. Unit sizes 08 through 16 have single blade dampers
12. Drawings not for installation purposes

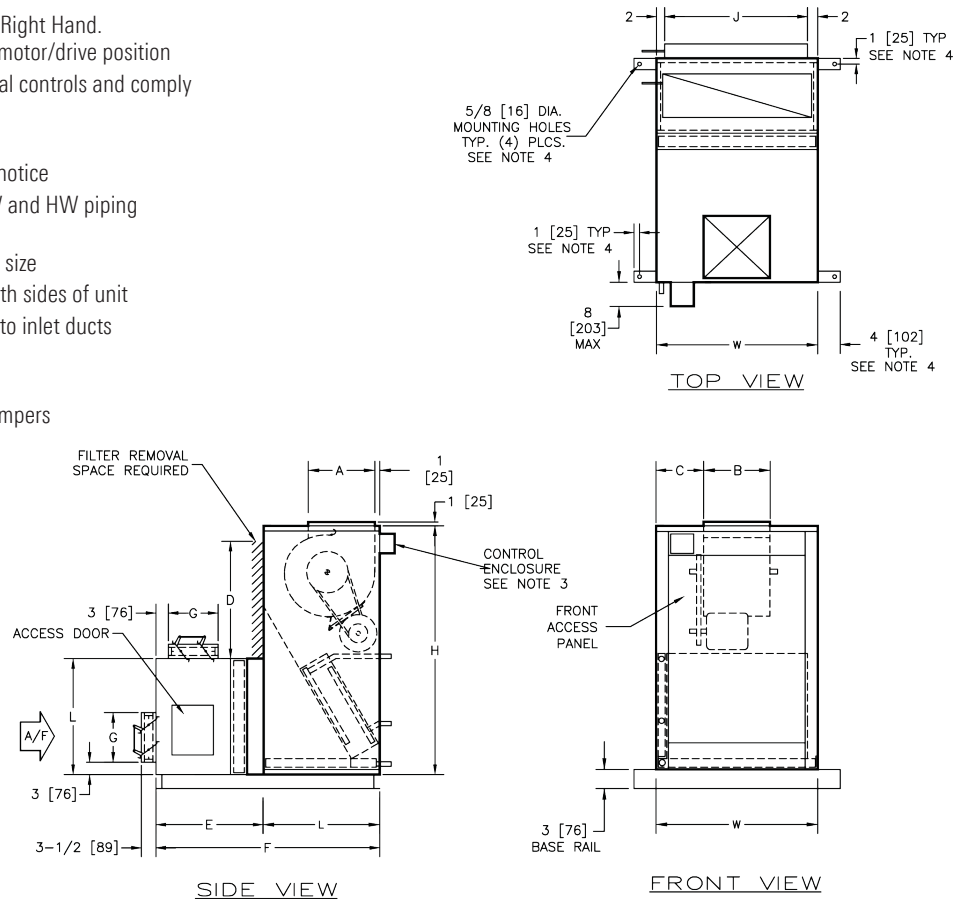

Dimensions													
Unit Size	Filter Size	Qty	H	W	L	A	B	C	D	E	F	G	J
08	16 x 20 x 2 [406 x 508 x 51]	1	46 [1168]	26 [660]	19 [483]	6 1/2 [165]	6 7/8 [175]	9 9/16 [243]	16 [406]	15 [381]	35 [889]	6 [152]	22 [559]
12	20 x 20 x 2 [508 x 508 x 51]	1	46 [1168]	26 [660]	21 [533]	7 1/2 [190]	8 1/4 [210]	8 7/8 [225]	20 [508]	18 [457]	40 [1016]	9 [229]	22 [559]
16	24 x 24 x 2 [610 x 610 x 51]	1	54 [1372]	29 [737]	25 [635]	7 1/2 [190]	10 1/4 [260]	9 3/8 [238]	24 [610]	18 [457]	44 [1118]	9 [229]	25 [635]
20	24 x 24 x 2 [610 x 610 x 51]	1	54 [1372]	29 [737]	28 [711]	11 3/8 [289]	13 1/4 [337]	7 7/8 [200]	24 [610]	21 [533]	50 [1270]	12 [305]	25 [635]
25	24 x 24 x 2 [610 x 610 x 51]	1 Each	60 [1524]	39 [991]	28 [711]	13 1/2 [343]	12 7/8 [327]	13 1/16 [332]	24 [610]	21 [533]	50 [1270]	12 [305]	35 [889]
30	12 x 24 x 2 [305 x 610 x 51]	1 Each	60 [1524]	39 [991]	28 [711]	15 1/6 [387]	15 [381]	12 [305]	24 [610]	21 [533]	50 [1270]	12 [305]	35 [889]

# TBL/TBS BLOWER COIL UNITS REDUCED-FOOTPRINT, VERTICAL

## Dimensional Data

### TBL With Blow-thru Electric Heat

Notes:

1. All dimensions are inches [millimeters] +/- 1/4" [6mm]. Metric values are soft conversions.
2. Left hand unit shown. Motor/drive location may be specified Left or Right Hand. Standard control enclosure location matches motor/drive position
3. Provide sufficient clearance to access electrical controls and comply with all applicable codes and ordinances
4. Optional base rail designed for use with floor mount vibration isolators
5. Blow-thru electric heat may not be combined with supply plenum or discharge section

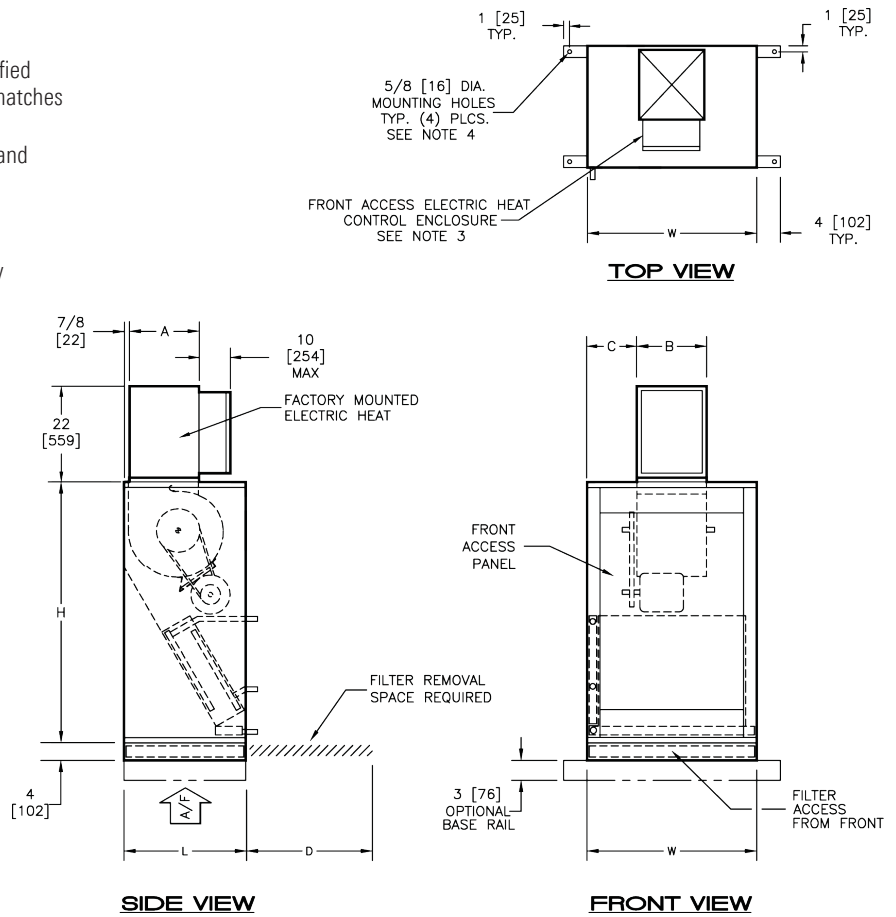

Unit Size	Filter Size	Qty	Dimensions						
			H	W	L	A	B	C	D
08	16 x 20 x 2 [406 x 508 x 51]	1	46 [1168]	26 [660]	19 [483]	8 7/8 [226]	11 7/8 [302]	7 1/16 [180]	16 [406]
12	20 x 20 x 2 [508 x 508 x 51]	1	46 [1168]	26 [660]	21 [533]	8 7/8 [226]	11 7/8 [302]	7 1/16 [180]	20 [508]
16	24 x 24 x 2 [610 x 610 x 51]	1	54 [1372]	29 [737]	25 [635]	10 7/8 [277]	12 [305]	8 1/2 [216]	24 [610]
20	24 x 24 x 2 [610 x 610 x 51]	1	54 [1372]	29 [737]	28 [711]	13 7/8 [353]	14 [356]	7 1/2 [190]	24 [610]
25	24 x 24 x 2 [610 x 610 x 51]	1 Each	60 [1524]	39 [991]	28 [711]	13 7/8 [353]	16 5/8 [422]	11 1/16 [281]	24 [610]
30	12 x 24 x 2 [305 x 610 x 51]	1 Each	60 [1524]	39 [991]	28 [711]	15 5/8 [397]	16 5/8 [422]	11 1/16 [281]	24 [610]

## Dimensional Data

### Discharge Plenum with Double Deflection Grille (TBL and TBS)

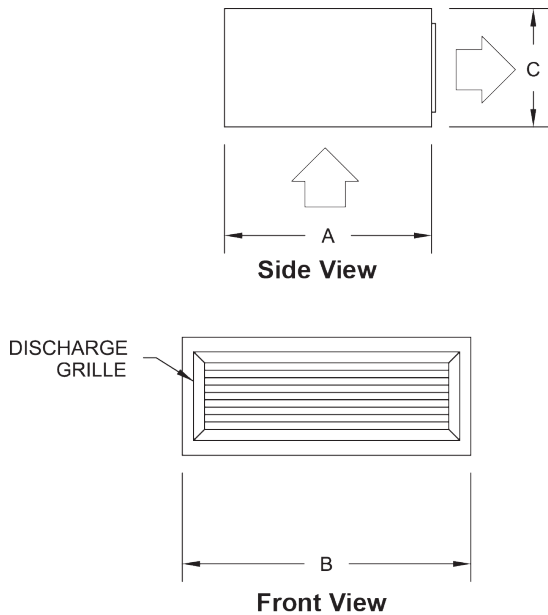

Dimensions				
Unit Size	A	B	C	Supply Grille
08	19 [483]	26 [660]	12 [305]	18 x 8 [457 x 203]
12	21 [533]	26 [660]	12 [305]	22 x 8 [559 x 203]
16	25 [635]	29 [737]	14 [356]	24 x 10 [610 x 254]
20	28 [711]	29 [737]	16 [406]	24 x 12 [610 x 305]
25	28 [711]	39 [991]	16 [406]	30 x 12 [762 x 305]
30	28 [711]	39 [991]	16 [406]	36 x 12 [914 x 305]

#### Notes:

1. All dimensions are inches [millimeters] +/- 1/4" [6mm]. Metric values are soft conversions.
2. All drawings subject to change without prior notice
3. Discharge plenum shipped attached to unit
4. Discharge plenum includes double deflection discharge grille; location is front as shown
5. Discharge plenum may not be combined with blow through electric heat

### Return Plenum (Model TBL)

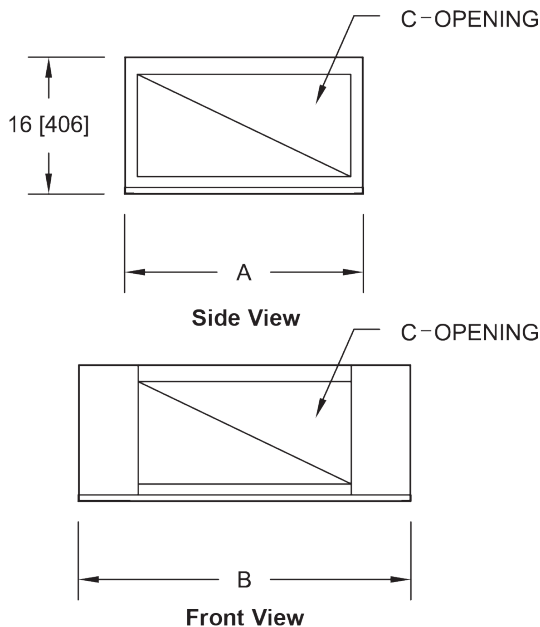

Dimensions			
Unit Size	A	B	C-Opening
08	19 [483]	26 [660]	9 x 16 [229 x 406]
12	21 [533]	26 [660]	9 x 18 [229 x 457]
16	25 [635]	29 [737]	9 x 22 [229 x 559]
20	28 [711]	29 [737]	12 x 22 [305 x 559]
25	28 [711]	39 [991]	12 x 25 [305 x 635]
30	28 [711]	39 [991]	12 x 25 [305 x 635]

#### Notes:

1. All dimensions are inches [millimeters] +/- 1/4" [6mm]. Metric values are soft conversions.
2. All drawings subject to change without prior notice
3. Bottom and back panels are fixed. Both side panels are removable and can be used to cover the front opening



# TBL/TBS BLOWER COIL UNITS REDUCED-FOOTPRINT, VERTICAL

## Dimensional Data

### Discharge Section with Heating Coil (TBL and TBS)

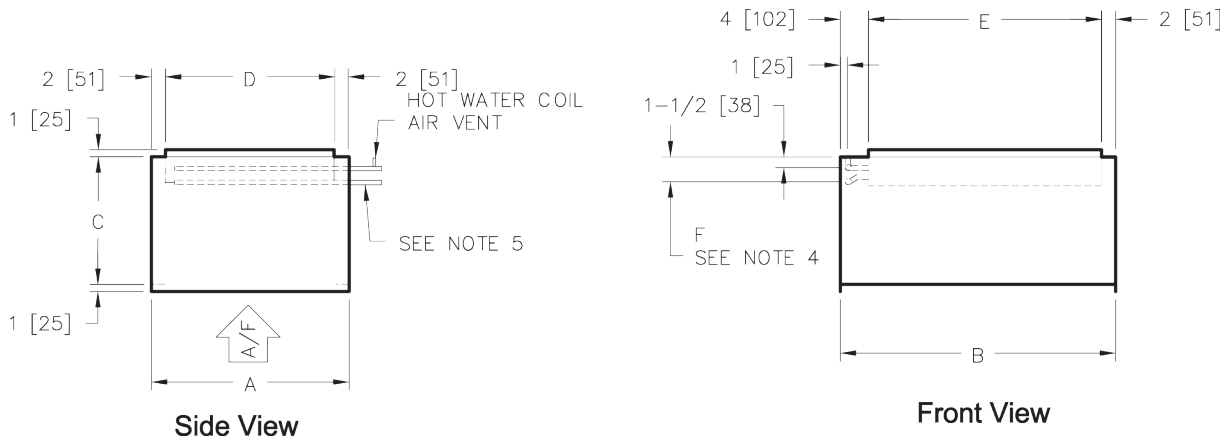

Unit Size	Dimensions									Weight (3) lbs. [kg]
	A	B	C	D	E	F (4)				
						Hot Water		Steam		
						1 Row	2 Row	1 Row	2 Row	
08	19 [483]	26 [660]	12 [305]	15 [381]	20 [508]	2 3/4 [70]	2 3/4 [70]	2 3/4 [70]	2 3/4 [70]	35 [16]
12	21 [533]	26 [660]	12 [305]	17 [432]	20 [508]	2 3/4 [70]	2 3/4 [70]	2 3/4 [70]	2 3/4 [70]	37 [17]
16	25 [635]	29 [737]	14 [356]	21 [533]	23 [584]	2 3/4 [70]	3 [76]	2 3/4 [70]	3 1/4 [83]	49 [22]
20	28 [711]	29 [737]	16 [406]	24 [610]	23 [584]	2 3/4 [70]	3 [76]	3 1/4 [83]	3 1/4 [83]	53 [24]
25	28 [711]	39 [991]	16 [406]	24 [610]	33 [838]	2 3/4 [70]	3 [76]	3 1/4 [83]	3 3/4 [95]	76 [35]
30	28 [711]	39 [991]	16 [406]	24 [610]	33 [838]	3 [76]	3 1/4 [83]	3 3/4 [95]	3 3/4 [95]	80 [36]

### COIL CONNECTION SIZES

Unit Size	Coil Type					
	Hot Water		Steam			
	1 Row	2 Row	1 Row		2 Row	
			Supply	Condensate	Supply	Condensate
08	5/8 [16]	5/8 [16]	1 1/8 [29]	7/8 [22]	1 1/8 [29]	7/8 [22]
12	5/8 [16]	5/8 [16]	1 1/8 [29]	7/8 [22]	1 1/8 [29]	7/8 [22]
16	5/8 [16]	5/8 [16]	1 1/8 [29]	7/8 [22]	1 3/8 [35]	1 1/8 [29]
20	5/8 [16]	5/8 [16]	1 3/8 [35]	1 1/8 [29]	1 3/8 [35]	1 1/8 [29]
25	5/8 [16]	7/8 [22]	1 3/8 [35]	1 1/8 [29]	1 5/8 [41]	1 1/8 [29]
30	7/8 [22]	7/8 [22]	1 5/8 [41]	1 1/8 [29]	1 5/8 [41]	1 1/8 [29]

#### Notes:

- All dimensions are inches [millimeters] +/- 1/4" [6mm]. Metric values are soft conversions.
- This section required with 6 row cooling in conjunction with hot water and all steam heating
- Weight with 2 row dry coil
- Coil connection dimension + 1/2" [13mm]
- Hot Water Coils: Supply, bottom; Return, top. Steam Coils: Supply, top; Condensate, bottom
- Discharge section may not be combined with blow-thru electric heat
- All drawings subject to change without notice

## Guide Specifications

### GENERAL

Furnish and install Titus Model TBL/TBS Belt Drive Blower Coil Units where indicated on the plans and specifications. Units shall be completely factory assembled and tested and shipped as one piece except where noted.

All units shall be capable of meeting or exceeding the scheduled capacities for cooling, heating and air delivery. All unit dimensions for each model and size shall be considered maximums.

All units shall be designed with coils, fans, motor/drive and drain pan completely contained within the unit cabinet.

Electric heat to be in the blow-thru configuration.

Hot water and steam coils to be in a blow-thru configuration when installed in a discharge plenum.

Units shall be ETL listed in compliance with UL/ANSI Standard 1995.

All unit coils shall meet or exceed the scheduled cooling and heating capacity, selected and rated in accordance with AHRI 410.

### CONSTRUCTION

All units shall be fabricated of minimum 18 gauge galvanized steel, able to withstand a 125 hour salt spray test per ASTM B-117. Panels shall be die-formed "multibend" construction for optimum strength and rigidity. All exterior panels shall be single wall. Insulation shall be 1 inch thick, 1.6 pound per cubic foot scrim reinforced foil faced insulation, glued and pinned with mechanical fasteners, and seams are foil taped for maximum positive adhesion. Insulation must comply with UL 181, ASTM-C-1071, NFPA 90A & 90B and meets bacteriological standard ASTM-C-665 and C-1136 for mold, mildew and humidity resistance. Maximum thermal conductivity shall be 0.24. All units shall have minimum 1" duct collars on discharge and return.

The access panel shall be fully insulated and attached with standard lift and turn fasteners on at least two opposite sides. No coil or drain piping or electrical connections shall pass through any access panel.

Each unit shall be furnished with a one-piece heavy gauge (Galvanized steel) (stainless steel) drain pan with welded corner construction.

(Rubber-in-shear) (Spring) type unit mounting vibration isolators shall be provided by the unit manufacturer.

### FAN ASSEMBLY

All units shall be furnished with DWDI forward curved centrifugal blowers statically and dynamically balanced for smooth operation. All blower wheels shall have two setscrews and shall be mounted on solid steel shafting rotating in ball bearings with a minimum design average life (L50) of 100,000 hours. All blower assemblies shall have resilient mounted cartridge type permanently lubricated ball bearings.

### FAN MOTOR & DRIVE ASSEMBLY

All fan motors shall be standard NEMA design motors of the horsepower listed in the equipment schedule. All motors shall be 1750 RPM, 60-hertz (ODP) (ODP E+) single speed motors rated for continuous duty. All motors shall be reversible rotation type. Three phase motors shall be "across-the-line" start type in 56 Frame size up through two horsepower. Three horsepower shall be standard "T" frame with rigid mount.

All motors shall be mounted on an adjustable base.

All motor wiring is to be terminated in a junction box, external to the unit casing.

All fan drive assemblies shall include an adjustable pitch motor pulley, a fixed pitch blower pulley and a standard cross section "V-belt". All fan drives shall be selected at a minimum service factor of 1.2.

### COILS

All unit coils shall be rated in accordance with AHRI 410.

All coils shall be 1/2" O.D. seamless copper tubes with collared and corrugated aluminum fins. All tubes shall be mechanically expanded to provide an efficient bond between tube and fin. All water coils shall be provided with a manual air vent fitting to allow for coil venting. Valve core type vent fittings shall not be accepted.

All chilled water, hot water, and direct expansion (DX) coils shall have 0.0055" thick aluminum fins and 0.016" tube wall thickness. All steam coils shall have 0.0055" thick aluminum fins and 0.025" tube wall thickness.

All steam coils shall be suitable for temperatures above 35°F and 15-psig maximum operating pressure.

All coils shall be hydrostatically tested with air under water at 450 PSIG minimum pressure and rated for a maximum of 300 PSIG working pressure at 200°F.

# TBL/TBS BLOWER COIL UNITS REDUCED-FOOTPRINT, VERTICAL

## Guide Specifications

DX coils shall be tested to 450 pressure and factory sealed and charged with a minimum of 5-psig nitrogen or refrigerated dry air. A field furnished and installed thermal expansion valve (TXV) can be mounted directly to the refrigerant distributor.

### COIL OPTIONS

Coil casing shall be fabricated from stainless steel. Provide automatic air vents, in lieu of manual air vents. Tube wall thickness shall be 0.025" on chilled water, hot water, and direct expansion coils.

### FILTER RACK ASSEMBLY

All units shall be furnished with a flat filter rack designed to accept 2" nominal, standard sized, throwaway filters. One complete set of spare throwaway filters shall be provided for each unit.

### FILTER OPTIONS

Unit shall be furnished with a flat filter rack designed to accept 2" nominal, standard sized, pleated filters. One complete set of spare pleated filters shall be provided for each unit.

### INLET DAMPER SECTION – MODEL TBS ONLY

Where shown on the plans, the unit manufacturer shall furnish a fully insulated mixing box section (factory assembled and installed inlet damper section) to be mounted next to the unit on base rail (unit & mixing box). The mixing box section shall include heavy gauge formed steel blade dampers in a heavy gauge steel frame with extruded vinyl blade seals and flexible metal jamb seals. Damper drive linkage shall be factory furnished and installed by the unit manufacturer. A field furnished and installed damper actuator can be mounted directly to the damper shaft.

### RETURN PLENUM SECTION – MODEL TBL ONLY

Where shown on the plans, the unit manufacturer shall furnish a fully insulated return air plenum section to be mounted under the unit in the field. Return plenum will have a solid bottom & back panel with right, left, and front openings all with the same dimensions. The return plenum right and left openings will be covered with a sheet metal panel that can be removed and used to cover the front opening (for field modification) or discarded when more than one opening is required. The return air can be from the (front and/or sides) (rear and/or sides).

### DISHARGE PLENUM SECTION

Where shown on the plans, the unit manufacturer shall furnish and mount a fully insulated discharge plenum section complete with a double deflection discharge grille (cannot be used with discharge heating coil plenum options).

### ELECTRICAL CONTROL

The unit fan motor shall be completely factory wired to an external electrical enclosure. Each unit shall include fan control package with 24-volt control voltage. Each unit shall include motor circuit fusing, control circuit transformer and terminal strip for connection of field wiring. A main incoming power (non-fused) (fused) disconnect switch shall be factory furnished and wired by the unit manufacturer for single point power connection.

### ELECTRIC HEAT SECTION

Where shown on the plans, the unit manufacturer shall furnish an electric resistance heating assembly with the heating capacity, voltage and stages as shown in the schedule. The heater assembly shall be designed and rated for installation to the blower coil unit in the blow-thru configuration without the use of duct extensions or transitions between the unit and the heater assembly.

The heater assembly shall be factory assembled to the blower coil unit and completely factory wired for single point power connection to the unit. The heater/unit assembly shall be listed for zero clearance meeting all N.E.C. requirements and be ETL listed in compliance with UL/ANSI Std. 1995.

All heating elements shall be of open coil design using Ni-Chrome wire mounted in ceramic insulators and housed in an insulated heavy gauge galvanized steel housing. All elements shall terminate in a machine staked stainless steel terminal secured with stainless steel hardware. The element support brackets shall be spaced no greater than 3-1/2" on center. All internal wiring shall be rated for 105°C minimum.

All heaters shall include over temperature protection. All heaters shall include a non-adjustable airflow switch.

An incoming line power distribution block shall be provided. The power distribution block shall be designed to accept incoming power wiring capable of carrying 125% of the calculated load current.

In addition to the above, electric heaters shall include the following options:

- Door interlocking disconnect switch (non-fused) (with main fusing)
- Fusing (main) (per stage) Magnetic contactors wired for disconnecting operation.
- Fan control package with heater interlock contacts (required for single point power connection)

## Notes

---





605 Shiloh Road  
Plano TX 75074  
office: 972.212.4800  
fax: 972.212.4884

Redefine your comfort zone.™ | [www.titus-hvac.com](http://www.titus-hvac.com)

